

**INTERNATIONAL JOURNAL OF ENGINEERING SCIENCES & RESEARCH
TECHNOLOGY****POWER OSCILLATION CONTROL IN POWER SYSTEM BY ANFIS BASED
UNIFIED POWER FLOW CONTROLLER ALONG WITH STABILIZATION****Chitrasen Gabel*, Dr. Dharmendra Kumar Singh**

* M. Tech. Scholar Dr. C.V. Raman Institute of Science & technology Kota, Bilaspur (C.G.), India
Head of Department (Department of Electrical & Electronics Engineering) Dr. C.V. Raman Institute
of Science & technology Kota, Bilaspur (C.G.), India

DOI: 10.5281/zenodo.221002

ABSTRACT

In the present era, the power system has become a vital part to provide stability enhancement. The stability of a power system depends on how low frequency disturbances which are typically in the frequency range of 0.2 to 3.0 Hz, accurately find out and cleared so that quick restoration and maintains a stability enhancement of power is accomplished. Loss of synchronism and stability enhancement are needs to be performed using ANFIS controlled based excitation of power system [3]. The significant factors which affect the operation of power system during the occurrence of low frequency disturbances are mainly; Loss of synchronism which might be excited by the disturbances in the system or, in some cases, might even build up spontaneously. These factors can be analyzed to find out the occurrence of the low frequency disturbance in the power line operation. Various techniques like Power System Stabilizer with algorithm based or logic controlled based, UPFC has been used in past to find out and cleared the different low frequency disturbances occurred in the transmission line. The proper selection of enhanced feedback is a very tedious and time consuming task and also requires brief knowledge of the system configuration. To avoid the drawbacks of conventional power system stabilizer with algorithm or logic controller based techniques, this dissertation proposed, an efficient and robust technique of stability enhancement using ANFIS based power system excitation. The advantage of the proposed technique is that; it improves the overshoot of power and reduced the time for low frequency oscillations [1]. The ANFIS based stability enhancement accuracy of proposed technique has been verified using MATLAB/Simulink 2013(a) software. The obtained results show that the proposed technique is efficient in stability enhancement of all type of loss of synchronism and hence reliable tool for low frequency disturbance occurred in power system.

KEYWORDS: Power System Stabilizer, Adaptive Neuro Fuzzy Interface, Unified Power Flow Controller, Automatic Voltage Regulator, Multi machine infinite bus, Excitation System.

INTRODUCTION

With the development of interconnection of large electric power systems there have been spontaneous system oscillations at low frequencies in the order of several cycles per minute. These low frequency oscillations are predominantly due to the lack of damping of mechanical mode of the system. Since power oscillation is a sustained dynamic event, it is necessary to vary the applied compensation to counteract the accelerating and decelerating swings of the disturbed machine. Several years the power system stabilizer act as a common control approach to damp the system disturbances. However, in some operating conditions, the conventional stabilizer may fail to stabilize the power system, especially in low frequency disturbances (0.2 Hz to 3 Hz) [2]. These disturbance may be local, inter area and global oscillation in power system. As a result, other alternatives have been suggested to ANFIS based Power System Stabilizer technique used to stabilize the system accurately which is more enhanced possible with FACTS devices. Among all FACTS devices the UPFC most popular controller due to its wide area control over power both active and reactive, it also gives the system to be used for its maximum thermal limit. It's primarily duty to control both the powers independently. It has been shown that all three parameters that can affect the real power and reactive power in the power system can be simultaneously and independently controlled just by changing the control schemes from one type to other in UPFC [6]. Moreover, the UPFC is executed for voltage provision and transient stability improvement by suppressing the low frequency disturbances. For example, in it has been shown that the UPFC is capable of inter-area oscillation damping by means of straight controlling the

UPFC's sending and receiving bus voltages. Therefore, the main aim of the UPFC is to control the active and reactive power flow through the transmission line with emulated reactance. It is widely accepted that the UPFC is not capable of damping the disturbances with its normal controller. As a result, ANFIS based controller UPFC is providing enhanced feedback from infinite bus for power system stabilizer that is the main purpose of enhanced excitation system. The auxiliary damping controller should be supplemented to the adaptive neuro fuzzy interface control of UPFC with Power System Stabilizer in order to retrieve the disturbances and improve the system stability.

SYSTEM MODEL

Modeling of Power System stabilizer

The system consists of two subsystems, the adaptive plant identifier for the generator and the Adaptive Neuro Fuzzy Interface System based Power System stabilizer, as shown in Fig. 1.

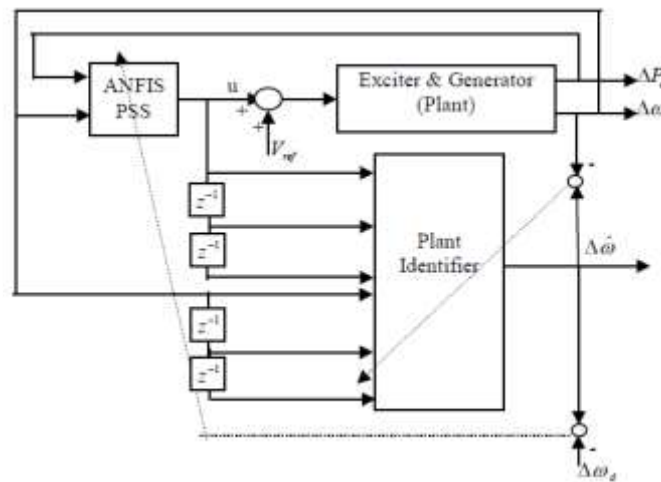

Fig. 1: Structure of Controlled System

There is no desired controller in this system. The parameters of the plant identifier are updated by the error between estimated and actual plant outputs, while the parameters of the Adaptive neuro fuzzy interface based Power system stabilizer are tuned by back propagating the error signal between the estimated plant output and the desired output. This output represent reduced the overshoot and time settling whose are come during low oscillations frequency (LFOs) [11].

Structure of ANFIS PSS

A zero-order Sugeno-type fuzzy controller with 49 rules is used for the ANFIS PSS whose block diagram is illustrated in Fig. 2. The input to the PSS is the speed deviation and the accelerating power, which are passed through a washout filter to eliminate any existing dc offset. The first scaling block maps the real input to the normalized input space in which the membership functions are defined. The second scaling block is used to map the output of the fuzzy inference system to the real output needed [7]. The fuzzy inference system consists of Fuzzification block which changes the crisp input into linguistic terms throughout membership functions.

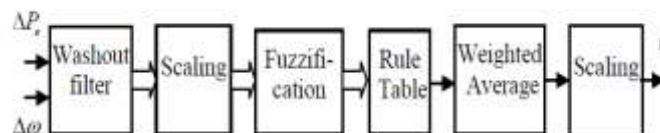

Fig. 2: Block Diagram of ANFIS Model

Fuzzification of ANFIS PSS

An only Sugeno type Fuzzification method is proposed for ANFIS; hence only this method is discussed here.

Sugeno fuzzy model

The Sugeno fuzzy model or TSK fuzzy model was proposed by Takagi, Sugeno, and Kang and was introduced in 1985. A typical fuzzy rule in a Sugeno fuzzy model has the form;

“IF x is A and y is B then z = f (x, y)”

Where A and B are fuzzy sets in the antecedent, while z = f (x, y) is a crisp function in the consequent. Usually z = f (x, y) is a polynomial in the input variables x and y, but it can be any function as long as it can appropriately describe the output of the model within the fuzzy region specified by the antecedent of the rule. When z = f (x, y) is a first-order polynomial, the resulting fuzzy inference system is called a first-order Sugeno fuzzy model. When f is a constant, we then have a zero-order Sugeno fuzzy model. Training data of ANFIS has been already discussed in above section 2.1.1.

Rule Table of ANFIS PSS

The rule table block and the weighted average block together are equivalent to the combination of the aggregator and defuzzifier blocks in a regular fuzzy inference system. the Adaptive Neuro fuzzy Interface System. A specific signal may have non-zero membership value in more than one set and a specific control signal may represent the contribution of more than one rule. The linguistic terms used for the membership function ranges are PB (Positive Big), PM (Positive Medium), PS (Positive Small), ZE (Zero), NS (Negative Small), NM (Negative Medium), and NB (Negative Big). The control rules design is based on the understanding of the role and effect of the controller [4]. The rule matrix is obtained as shown in Table I. Each rule represents a desired controller response to a particular situation. The table gives the initial value of the output of each rule.

Acceleration \ Speed	NB	NM	NS	ZE	PS	PM	PB
NB	NB	NB	NB	NS	ZE	ZE	PS
NM	NB	NB	NM	NS	ZE	PS	PM
NS	NB	NB	NM	ZE	PS	PM	PB
ZE	NB	NM	NS	ZE	PS	PM	PB
PS	NB	NM	NS	ZE	PM	PB	PB
PM	NM	NS	ZE	PS	PM	PB	PB
PB	NS	ZE	ZE	PS	PB	PB	PB

Table I: Initial premise and consequent parameters for Power System Stabilizer (ANFIS)

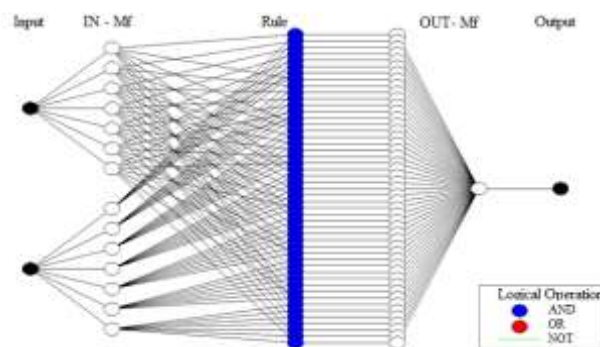

Fig. 3: ANFIS Architecture of PSS Controller

In this figure, IN, OUT and Rule are the input and output scaling factors, respectively. This network consists of four layers, with each layer representing a specific part in the ANFIS controller. The node function in the first layer represents the Gaussian membership function. The second layer is to calculate the firing strength of each rule which is the same as AND operation, hence the node function is a “min” function. The third layer calculates the normalized firing strength of each rule with the node function given by above equation, and the fourth layer combines the output of all rules to get the overall output of the controller with its node function given by above model [14].

Modeling of Unified Power Flow Controller

A Unified Power Flow Controller (UPFC) is an electrical device for providing fast-sensation on high-voltage electricity transmission networks. It uses a pair of three-phase controllable bridges to produce current that is injected into a transmission line using a series transformer. The controller can control active and reactive power flows in a transmission line. The UPFC uses solid state devices, which provide functional flexibility, generally not attainable by conventional thyristor controlled systems. The UPFC is a combination of a static synchronous compensator (STATCOM) and a static synchronous series compensator (SSSC) coupled via a common DC voltage link. The UPFC allows a secondary but important function such as stability control to suppress power system oscillations improving the transient stability of power system compensation without an external electric energy source [9]. The UPFC, by means of angularly unconstrained series voltage injection, is able to control, concurrently or selectively, the transmission line voltage, impedance and angle or alternatively, the real and reactive power flow in the line. The UPFC may also provide independently controllable Shunt reactive compensation. Viewing the operation of the UPFC from the standpoint of conventional power transmission based on reactive shunt compensation, series compensation and phase shifting, the UPFC can fulfill all these functions and thereby meet multiple control objectives by adding the injected voltage with appropriate amplitude and phase angle, to the terminal voltage [5]. The UPFC provides complete control over power flow in the line. A circuit equivalent diagram of the UPFC is show in the fig. 5.

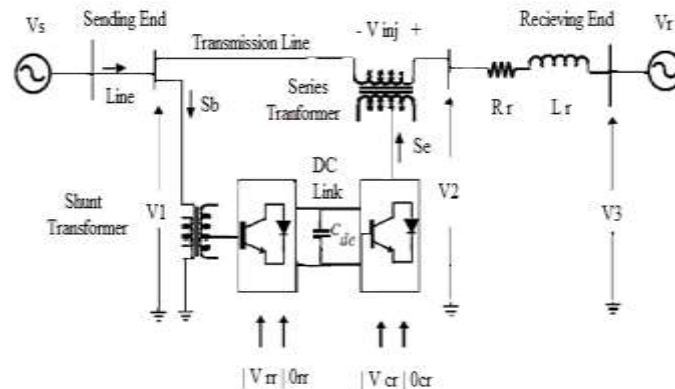

Fig.5: Connection diagram of UPFC with transmission line

The UPFC consists of two voltage sourced converters, as illustrated in Fig 5 these back to back converters, labeled "STATCOM" and "SSSC" in the figure, are operated from a common dc link provided by a DC storage capacitor. As indicated before, this arrangement functions as an ideal AC to AC power converter in which the real power can freely flow in either direction between the AC terminals of the two converters, and each converter can independently generate or absorb reactive power at its own AC output terminal. SSSC provides the main function of the UPFC by injecting a voltage V_{inj} with controllable magnitude V_{cr} and phase angle θ_{cr} in series with the line via an insertion transformer. This injected voltage acts essentially as a synchronous ac voltage source. The transmission line current flows through this voltage source resulting in reactive and real power exchange between it and the AC system. The reactive power exchanged at the AC terminal is generated internally by the converter. The real power exchanged at the AC terminal is converted into DC power which appears at the DC link as a positive or negative real power demand. The basic function of STATCOM is to supply or absorb the real power demanded by SSSC at the common DC link to support the real power exchange resulting from the series voltage injection. This DC link power demand of SSSC is converted back to AC by STATCOM and coupled to the transmission line bus via a shunt connected transformer. In addition to the real power need of SSSC, STATCOM can also generate or absorb controllable reactive power, if it is desired, and thereby provide independent shunt reactive compensation for the line [6]. It is important to note that whereas there is a closed direct path for the real power negotiated by the action of series voltage injection through STATCOM and SSSC back to the line, the corresponding reactive power exchanged is supplied or absorbed locally by SSSC and therefore does not have to be transmitted by the line. Thus, STATCOM can be operated at a unity power factor or be controlled to have a reactive power exchange with the line independent of the reactive power exchanged by SSSC. Obviously, there can be no reactive power flow through the UPFC DC link.

ANFIS based Unified Power Flow Controller

To maintain good dynamic response at various operating conditions with the four possible choices of UPFC control signal, the controller gains need to be adapted based on system conditions. An adaptive neuro fuzzy inference system has been used in this work to adapt the controller gains of UPFC damping controller. The various steps involved are elaborated with reference to UPFC installed in two machine infinite bus system.

Determination of initial fuzzy structure

In this thesis, UPFC is control active and reactive power in system by Adaptive Neuro Fuzzy Interface System (ANFIS) control technology. These controlled powers synchronize infinite bus system and provide feedback to excitation system of synchronous generator by ANFIS control technology. For UPFC the input to the proposed fuzzy inference system is taken as the deviation between active and reactive power (Δpq), and the output as the damping control signal, (Δu) same as in the case of constant gain controller. The linguistic rules, considering the dependence of the controller output on the controlling signal, are used to build the initial fuzzy inference structure [9].

An increasing trend in active and reactive power deviation results in excess accelerating power and the control action should be in such a way to promote the power flow to maintain the power balance and vice-versa.

$\Delta q \backslash \Delta p$	NB	NM	NS	ZE	PS	PM	PB
NB	NB	NB	NB	NS	ZE	ZE	PS
NM	NB	NB	NM	NS	ZE	PS	PM
NS	NB	NB	NM	ZE	PS	PM	PB
ZE	NB	NM	NS	ZE	PS	PM	PB
PS	NB	NM	NS	ZE	PM	PB	PB
PM	NM	NS	ZE	PS	PM	PB	PB
PB	NS	ZE	ZE	PS	PB	PB	PB

Table II: Initial premise and consequent parameters for ANFIS (UPFC)

RESULT AND DISCUSSION

ANFIS based controller UPFC with Power System stabilizer is good when compared to conventional controller for both normal and abnormal (switching, fault, heavy load) conditions, its response and also reduction of peak overshoot is observed with Adaptive Neuro Fuzzy Interface System. Consequently, simulation results show that ANFIS controller efficiently increases the damping rate and decreases the amplitude of transients.

The Case Study

- a. **Case i:** For normal load without vulnerable condition, the variation of speed deviation, field voltage, rotor angle, load angle, active and reactive power were analyzed for conventional PSS and Adaptive Neuro Fuzzy Interface UPFC with PSS Excitation System.
- b. **Case ii:** System was subjected to vulnerable (fault) condition, the variation of above mentioned cases were analyzed.

Normal Load without Fault:

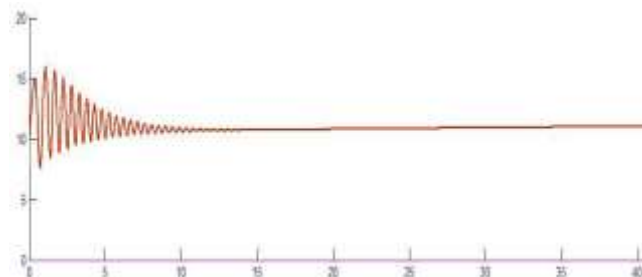

Fig 6 (a): Active Power at Normal Load Condition

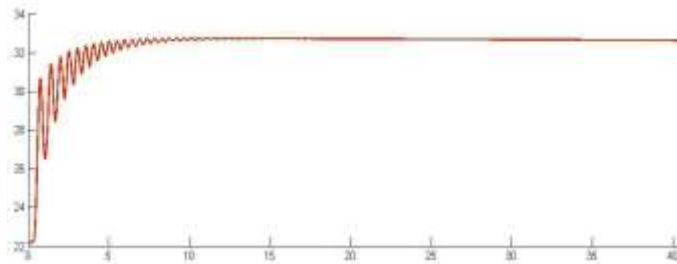

Fig 6 (b): Rotor Angle of Synchronous Generator at Normal Load Condition

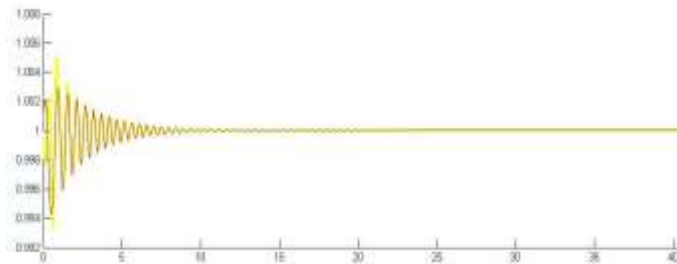

Fig 6 (c): Speed Deviation of Synchronous Generator at Normal Load Condition

Fault Condition:

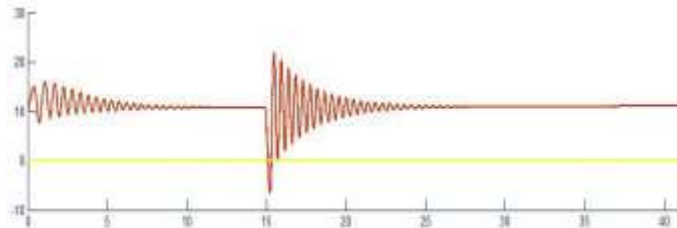

Fig 7 (a): Active Power at Fault Condition

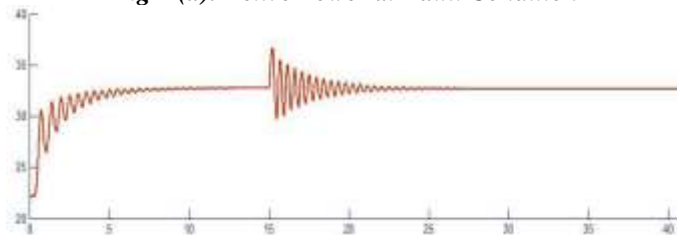

Fig 7 (b): Rotor Angle at Fault Condition

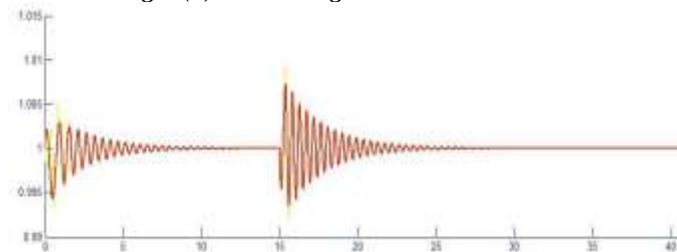

Fig 7 (c): Speed Deviation of Synchronous Generator at Fault Condition

CONCLUSION

In this paper work initially the effectiveness of power system stabilizer in damping power system stabilizer is reviewed. Then the ANFIS based UPFC with power system stabilizer is introduced by taking speed deviation and



acceleration of synchronous generator as the input signals to the ANFIS based PSS controller, voltage as the output signal. For ANFIS based UPFC controller by taking active and reactive power as the input signals, $(p, q)_{ref}$ as the output signal. ANFIS based UPFC with PSS shows the better control performance than power system stabilizer in terms of settling time and damping effect. Therefore, it can be concluded that the performance of ANFIS based UPFC with PSS is better than conventional PSS. However, the choice of membership functions has an important bearing on the damping of oscillations. From the simulation studies it shows that the oscillations are more pronounced in case of triangular membership functions. The response with Gaussian membership functions is comparable to triangular membership functions. However, the performance of ANFIS PSS with triangular membership functions is superior compared to other membership functions.

REFERENCES

- [1] Mohamed Jalaluddin, Dr. H.V.Saikumar and Dr.Bansilae “Performance Evaluation of Multi Machine Power System with Fuzzy Based Power System Stabilizer”, IEEE ICTAP, pp. 182-185, Dec 2015.
- [2] Manish Kushwaha and Mrs. Ranjeeta Khare “Dynamic Stability Enhancement of Power System using Fuzzy Logic Based Power System Stabilizer”, IEEE ICPEC, pp. 213-219, Feb 2013.
- [3] Ahmed Faizan Sheikh and Shelli K. Starrett “Comparison of Input Signal Choices for a Fuzzy Logic-based Power System Stabilizer”, IEEE ICPE, pp. 479-484, Dec 2015.
- [4] Renuka T K and Sobha Manakkal, “A Tuned Fuzzy Based Power System Stabilizer for Damping of Low Frequency Oscillations”, IEEE ICPP, pp. 156-162, June 2012.
- [5] Kamalesh Chandra Rout and Dr. P. C. Panda “An Adaptive Fuzzy Logic Based Power System Stabilizer For Enhancement of Power System Stability” IEEE ICIECR, pp. 175-179, Aug 2010.
- [6] R Gupta, D K Sambariya and R Gunjan, “Fuzzy Logic Based Robust Power System Stabilizer for a Multi-machine Power System”, IEEE ICIT, pp. 1037-1042, Dec 2006.
- [7] Anup Singh and I. Sen, “A novel fuzzy logic based power system stabilizer for a multi-machine system” in TENCON 2003. Conference on Convergent Technologies for Asia Pacific Region, pp. 1002-1006, Oct. 2003.
- [8] Emad Al-Mohammed, Khaled A. El-Metwally and Ahmed Bahgat “Spectral Monitoring Based Fuzzy Logic Stabilizer for Multi-Machine Power System”, IEEE AACC, pp. 3964 -3968, Jan. 2000.
- [9] Youcef Islam, Samir and Mohammed “Independent Power Flow Control and Dynamic Performance Enhancement by the UPFC”, IEEE ICEIT, pp. 234 -239, Dec. 2015.
- [10] Manju P and Subbiah V “Intelligent Control of Unified Power Flow Controller for Stability Enhancement of Transmission Systems”, IEEE ICTSP, pp. 61 - 64, August 2010.
- [11] S.V.Khatami, H.Soleymani and S.Afsharnia “Adaptive Neuro-Fuzzy Damping Controller Design for a Power System Installed with UPFC”, IEEE IPEC pp. 1046-1051, June 2010.
- [12] M. A. Abido A. T. Al-Awami Y. L. Abdel-Magid “Analysis and Design of UPFC Damping Stabilizers for Power System Stability Enhancement”, IEEE ISIE, pp. 2040 – 2045, July 2006.54
- [13] F Gopinath Balakrishnan and Suresh Kumar Sreedharan, “Transient Stability Improvement in Power System Using Unified Power Flow Controller (UPFC)”, IEEE ICCNT, pp. 2376- 2382, July 2013.
- [14] Nasser Talebi and Ali Akbarzadeh, “Damping of Low Frequency Oscillations in Power Systems with Neuro-Fuzzy UPFC Controller”, IEEE Student Conference on Research and Development, pp. 335- 339, Nov 2011.
- [15] Gundala Srinivasa Rao, Venugopal Reddy Bodha “Improvement of Transient stability in Power Systems with Neuro-Fuzzy UPFC” AJER, pp. 48 - 60, Feb 2011

CITE AN ARTICLE

Gabel, C., & Singh, D. K., Dr. (2017). POWER OSCILLATION CONTROL IN POWER SYSTEM BY ANFIS BASED UNIFIED POWER FLOW CONTROLLER ALONG WITH STABILIZATION. INTERNATIONAL JOURNAL OF ENGINEERING SCIENCES & RESEARCH TECHNOLOGY, 6(5), 579-585. doi:10.5281/zenodo.221002